

SPRINGS, REAR CJ-5,6,7,8, SCRAMBLER  
Figure 17-200

81J17 200

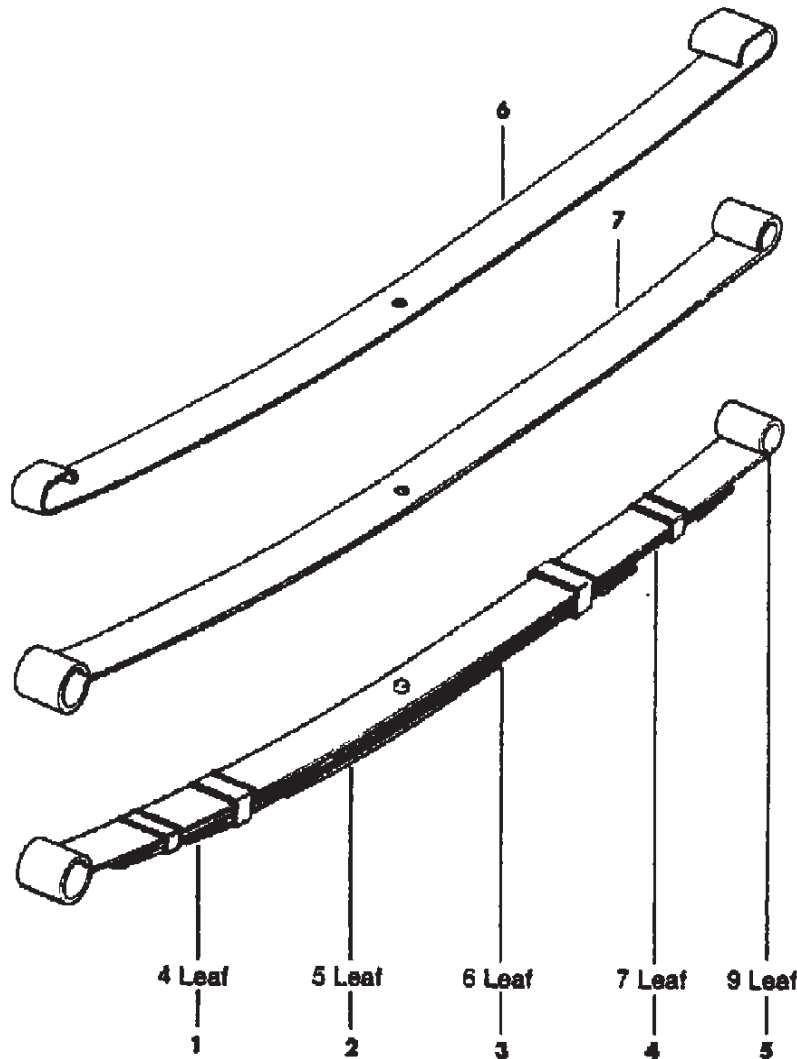

ITEM	PART NUMBER	QTY	BODY	MODEL	DESCRIPTION
1					SPRING ASSEMBLY, Light Duty *** Four Cylinder
	J535 6424	2			1981: Without Hardtop Enclosure, used with Serial No. 1 thru 057505
2					SPRING ASSEMBLY, Light Duty *** Four Cylinder
	J535 6425	2			1981: With Hardtop Enclosure, used with Serial No. 1 thru 057505
	J536 3330	2	85,87		1981: Without Hardtop Enclosure, used beginning with Serial No. 057506
	J536 3330	2	85		1982-83
	J536 3330	2	87		1982-86: Without Hardtop
	J536 3636	2	87		1982-86: Limited, Soft Ride
	J536 3935	2	87		Six Cylinder 1982-86: Limited, Soft Ride
3					SPRING ASSEMBLY, Light Duty *** Four Cylinder
	J536 3331	2	86,88		1981-86
	J536 3332	2	85		1981: Diesel, EXPORT, used beginning with Serial No. 057506
	J536 3332	2	85		1982-83: Diesel, EXPORT
	J536 3331	2	86,88		1981: Diesel, EXPORT, used beginning with Serial No. 057506
	J536 3332	2	87		1981: Gas, used beginning with Serial No. 057506
	J536 3332	2	87		1981: Diesel, EXPORT, without Hardtop Enclosure, Used beginning with Serial No. 057506
	J536 3331	2	87		1981: Diesel, EXPORT, with Hardtop Enclosure, used beginning with Serial No. 057506
	J536 3332	2	87		1982-86: Gas, with Hardtop Enclosure
	J536 3332	2	87		1982-86: Diesel, EXPORT, without Hardtop Enclosure
	J536 3331	2	87		1982-86: Diesel, EXPORT, with Hardtop Enclosure
	J536 3331	2	88		1982-86: Diesel, EXPORT
	J536 3332	2	85		Six Cylinder 1981: Used beginning with Serial No. 057506
	J536 3332	2	85		1982-83
	J536 3332	2	87		1981: Without Hardtop Enclosure, used beginning with Serial No. 057506
	J536 3331	2	87		1981: With Hardtop Enclosure, used beginning with Serial No. 057506
	J536 3332	2	87		1982-86: Without Hardtop Enclosure
	J536 3331	2	87		1982-86: With Hardtop Enclosure

MODEL CODES

16=Cherokee 2 Dr.(1981-83)	78=Cherokee 4WD-4 Dr.(1984-86)	64=Comanche 2WD-6 Ft. Box(1986)	25=J-10 Truck 7 Ft. Box(1981-84)
17=Cherokee 2 Dr.(1981-83)	85=CJ-5 (1981-83)	66=Comanche 2WD-7 Ft. Box(1986)	26=J10 Truck 8 Ft. Box(1981-86)
73=Cherokee 2WD-2 Dr.(1984-86)	86=CJ-6(1981)	63=Comanche 4WD-6 Ft. Box(1986)	27=J-20 Truck 8 Ft. Box(1981-86)
74=Cherokee 2WD-4 Dr.(1984-86)	87=CJ-7(1981-86)	65=Comanche 4WD-7 Ft. Box(1986)	15=Wagoneer 4 Dr.(1981-83)
18=Cherokee 4 Dr.(1981-83)	88=CJ-8, Scrambler(1981-86)	15=Grand Wagoneer 4 Dr.(1984-86)	75=Wagoneer 4WD-4 Dr.(1984-86)
77=Cherokee 4WD-2 Dr.(1984-86)			

BODY

CJ=CJ-5, CJ-6, CJ-7, CJ-8, Scrambler(1981-86)  
MJ=Comanche Pickup(1986)

STYLES

SJ=Wagoneer(1981-83), Grand Wagoneer(1984-86),  
Cherokee(1981-83), J-10, J-20(1981-86)  
XJ=Wagoneer(1984-86), Cherokee(1984-86)

AR = Use as Required - = Non Illustrated Part P.A.R. = Paint as Required

SPRINGS, REAR CJ-5,6,7,8, SCRAMBLER  
Figure 17-200

81J17 200

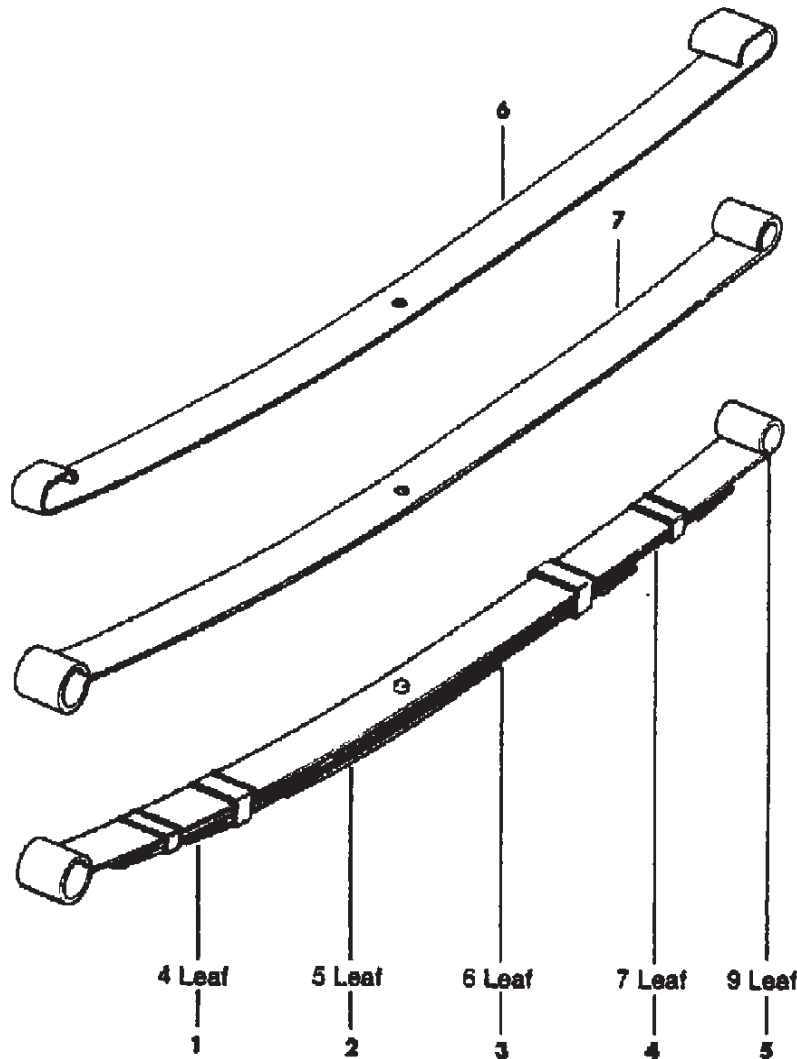

ITEM	PART NUMBER	QTY	BODY	MODEL	DESCRIPTION
					Eight Cylinder
	J536 3331	2	85		1981: Used beginning with Serial No. 057506
	J536 3331	2	87		1981: With Hardtop Enclosure, used beginning with Serial No. 057506
					<b>SPRING ASSEMBLY, Heavy Duty ***</b>
	J535 8940	2			1981: Used with Serial No. 1 thru 057505
	J536 3855	2	88		1982-86
					Four Cylinder
	J536 3334	2	85		1981: Used beginning with Serial No. 057506
	J536 3333	2	85		1981: Diesel, EXPORT, used beginning with Serial No. 057506
	J536 3854	2	85		1982-83
	J536 3333	2	85		1982: Diesel, EXPORT
	J536 3340	2	86,88		1981: Used beginning with Serial No. 057506
	J536 3340	2	86,88		1981: Diesel, EXPORT, used beginning with Serial No. 057506
	J536 3334	2	87		1981: Without Hardtop Enclosure, used beginning with Serial No. 057506
	J536 3333	2	87		1981: Diesel, EXPORT, without Hardtop Enclosure, used beginning with Serial No. 057506
	J536 3333	2	87		1981: With Hardtop Enclosure, used beginning with Serial No. 057506
	J536 3340	2	87		1981: Diesel, Export, with Hardtop Enclosure, used beginning with Serial No. 057506
	J536 3854	2	87		1982-86: Without Hardtop Enclosure
	J536 3333	2	87		1982: Diesel, EXPORT, Without Hardtop Enclosure
	J536 3853	2	87		1982-86: With Hardtop Enclosure
	J536 3340	2	87		1982: Diesel, EXPORT, with Hardtop Enclosure
	J536 3340	2	88		1982: Diesel, EXPORT
					<b>Six Cylinder</b>
	J536 3333	2	85		1981: used beginning with Serial No. 057506
	J536 3853	2	85		1982-83
	J536 3333	2	87		1981: Without Hardtop Enclosure, used beginning with Serial No. 057506
	J536 3340	2	87		1981: With Hardtop Enclosure, used beginning with Serial No. 057506
	<b>J536 3333</b>	2	<b>87</b>		<b>1982-86: Without Hardtop Enclosure</b>
	<b>J536 3340</b>	2	87		<b>1982-86: With Hardtop Enclosure</b>
					Eight Cylinder
	J536 3340	2	85		1981: Used beginning with Serial No. 057506
	J536 3333	2	87		1981: Without Hardtop, used beginning with Serial No. 057506

MODEL CODES

16=Cherokee 2 Dr.(1981-83)	78=Cherokee 4WD-4 Dr.(1984-86)	64=Comanche 2WD-6 Ft. Box(1986)	25=J-10 Truck 7 Ft. Box(1981-84)
17=Cherokee 2 Dr.(1981-83)	85=CJ-5 (1981-83)	66=Comanche 2WD-7 Ft. Box(1986)	26=J10 Truck 8 Ft. Box(1981-86)
73=Cherokee 2WD-2 Dr.(1984-86)	86=CJ-6(1981)	63=Comanche 4WD-6 Ft. Box(1986)	27=J-20 Truck 8 Ft. Box(1981-86)
74=Cherokee 2WD-4 Dr.(1984-86)	87=CJ-7(1981-86)	65=Comanche 4WD-7 Ft. Box(1986)	15=Wagoneer 4 Dr.(1981-83)
18=Cherokee 4 Dr.(1981-83)	88=CJ-8, Scrambler(1981-86)	15=Grand Wagoneer 4 Dr.(1984-86)	75=Wagoneer 4WD-4 Dr.(1984-86)
77=Cherokee 4WD-2 Dr.(1984-86)			

BODY

CJ=CJ-5, CJ-6, CJ-7, CJ-8, Scrambler(1981-86)  
MJ=Comanche Pickup(1986)

STYLES

SJ=Wagoneer(1981-83), Grand Wagoneer(1984-86),  
Cherokee(1981-83), J-10, J-20(1981-86)  
XJ=Wagoneer(1984-86), Cherokee(1984-86)

AR = Use as Required - = Non Illustrated Part P.A.R. = Paint as Required